

椭圆齿轮流量计



红器自控（江苏）有限公司
Hongqi Automation (Jiangsu) Co., LTD

HQLC 系列椭圆齿轮流量计 使用说明书

目录 Catalogue

- 一、概述 Summary
- 二、工作原理 Operation principle
- 三、结构 Structure
- 四、主要技术数据 Main technical datas
- 五、安装与使用 Installation and usage
- 六、误差调整 Error adjustment
- 七、故障的检查与排除 Fault examination and clearing
- 八、外形及安装 Profile and installation
- 九、HQLCB 型流量计技术参数 Technological parameter of HQLCB flowmeter
- 十、回零流量计简介 Brief introduction of returntozero flowmeter
- 十一、电子表头操作介绍

一、概述 Summary

HQLC 型椭圆齿轮流量计，系直读累积式液体流量计，HQLCB 型椭圆齿轮流量计，是在 HQLC 型流量计的基础上增加了发讯机构，可与本厂产品【微机流量控制仪】配套，广泛用于管道中液体流量（总量）或瞬时流量的测量和自动控制。由于它具有量程范围大，精度高，性能稳定。能测高温、高粘度液体，安装简易，操作方便等诸多优点，适用于石油开采、炼油、化工、商业、储油库等工业部门的液体计量。

HQLC oval gear flowmeter is a kind of direct-reading accumulating liquid flowmeter. HQLCB oval gear flowmeter adds transmitter mechanism on the basis of HQLC flowmeter. It can be equipped with our microcomputer flow controller. It is widely used in testing and auto control of total liquid flow and instant flux. It possesses many virtues such as large testing range, high precision, steady performance, testing high temperature and viscosity fluid, easy installation and convenient operation etc.. It is widely used for flux measurement in industrial field such as oil development, oil refining, chemical, commerce, oil storage.

二、工作原理 Operation Principle

液体流量的计量是在测量室内完成的（见图 1）。在测量室内有一对椭圆齿轮，在进口与出口两端液体压差作用下，一对椭圆齿轮在转轴上不停地转动，测出其转数即可知道流经仪表液体的总量。

如图 1 (a) 所示，一对椭圆齿轮 A、B 把进口与出口分开，在齿轮 A 与计量室内壁形成一个新月形空间的液体——称为“一份”（图上以阴影表示）。齿轮 A 有一转动力矩，而齿轮 B 上总力矩等于零。齿轮 A 带动齿轮 B 转动。图 1 (b) 是两轮的中位置，当转动到位置如图 1 (c) 所示时，齿轮 A 失去了转动力矩，而齿轮 B 获得了转动力矩，齿轮 B 带动齿轮 A 转动，如图 1 (d) 所示。

Measurement is made in the testing room. There is a pair of oval gear in it. The pair of oval gear will keep rotating on the axis under the role of liquid pressure difference between inlet and outlet. Liquid flux through the flowmeter will be known by testing gears' rotation number.

As it is showed in picture 1(a), the inlet and outlet are separated by a pair of oval gear A and B. There is crescent-shaped space between Gear A and inner wall of the testing room (It is showed as shadow in the picture). There is a rotating torque while the total torque on Gear B of the two gears. When the gears turn to the position showed in the picture 1(c), Gear A will lose rotating torque while Gear B will gain rotating torque. Gear A will be rotated by driven of Gear B. It is showed in the picture 1(d).



图 1 工作原理图

Operation Principle Picture

三、结构 Structure

HQLC 型椭圆齿轮流量计主要由计量室、密封机构和计数机构组成。

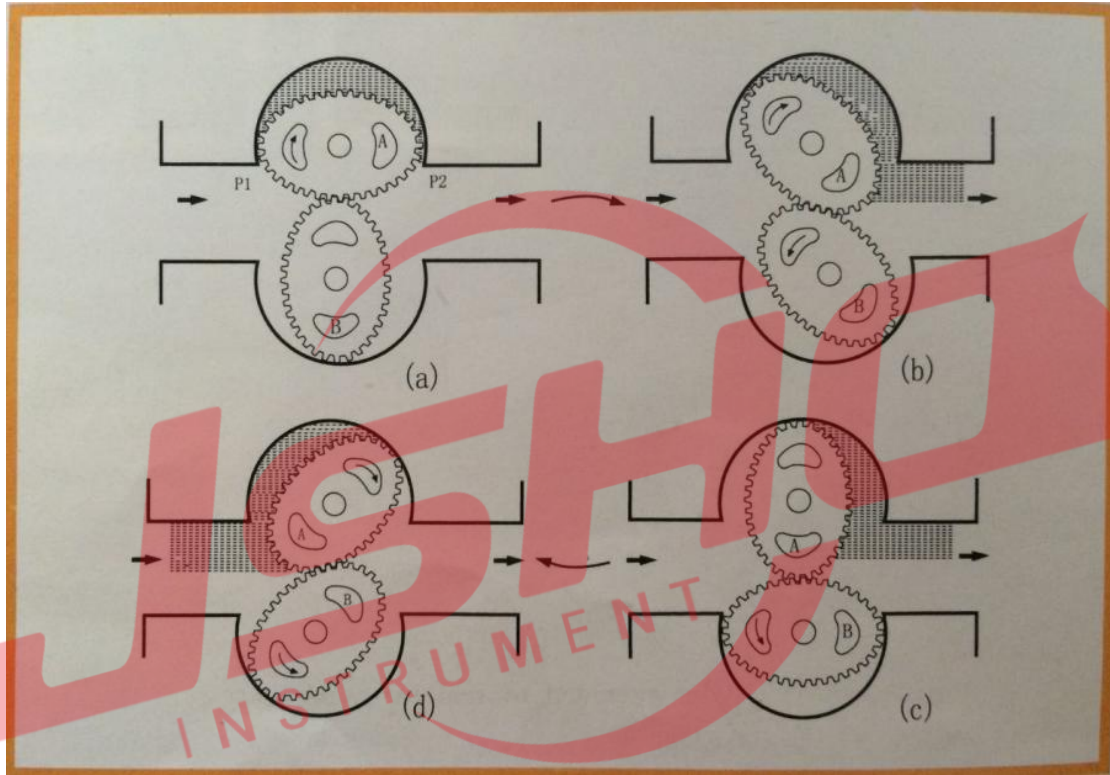
1、计量室：仪表躯壳（1）（图 2、图 3，下同）由铸铁制成，它的内腔与盖板（4）组成测量室。测量室内有两根不锈钢轴（2），一对椭圆齿轮（3）就套上轴上，靠流量计进出口处的压力差推动而旋转，从而不断地把进口处的液体经新月形空腔计量后送到出口处，每旋转一周，累计出四倍新月形空间的体积。椭圆齿轮与测量室内壁的间隙很小，仅几十微米，以减少仪表的泄漏量。

2、密封机构：仪表的测量室是密封的。小口径流量计采用永久性磁性密封机构（见图 2）：由隔板（8）将主动永久磁铁（6）、被动永久磁铁（7）分开。该结构灵敏度高，密封可靠；大口径流量计采用聚四氟乙烯塑料作填料密封（见图 3）：通过调节螺母（8）来改变弹簧（7）的压缩量，使密封衬垫（6）伸张，达到密封目的。该结构比较简单，调整方便。

3、计数机构：仪表的计数机构包括传统轮系、传动比调整机构和结算机构。一对椭圆齿轮旋转的总数、以及旋转的快慢经传动轮系（10）变速后传递给积算机构（11）的指针及字轮，即可知道通过管道中的液体问题和瞬时流量。传动比调整机构则用来调整修正仪表误差（见图 6）

HQLCB 型椭圆齿轮流量计，是在 HQLC 型椭圆齿轮流量计的计数机构中安装上电脉冲发信器，即在 HQLC 型流量计密封处的传动轴上安装了一块带有永久磁铁的圆盘，新型磁敏感集成传感器安装在计数器上。该传感器具有寿命长、抗干扰能力强、工作频率宽、无火花、不怕油污和灰尘、体积小、安装方便等优点，当磁铁接近于它的感应面达到动作距离时，即可无接触地产生可靠的检测信号。

The Model HQLC oval gear flowmeter mainly consists of testing room, sealing mechanism and counting mechanism.

1. Testing room: outcover (1) of instrument (see picture 2, 3; same as pictures later) is made by cast iron. Inner space and the board (4) consists of the testing room. There are 2 stainless steel axes (2) and a pair of oval gear (3) is sleeved on the axes. The liquid from the inlet will be sent to the outlet through the crescent-shaped space by the gears' turn which is driven by pressure difference between inlet and outlet in flowmeter. Four times volume of crescent-shaped space will be accumulated while the gear makes one revolution round. The space between oval gear and inner wall of the testing room is very small with tens of micro-meter only to decrease leak of the instrument.

2. Sealing mechanism: The testing room is sealed. The permanent magnetic sealing mechanism is adopted on the small caliber flowmeter (See picture 2). The partition (8) separates the active and passive permanent magnet (6) (7). Sensitivity of the structure is high and seal is solid. Polytetrafluoroethylene plastic is used as packing seal for the big caliber flowmeter (See picture 3). The sealing lining (6) will be extended to seal by change of spring (7) compression through adjusting the nut (8). The structure is rather simple and convenient for adjustment.

3. Counting mechanism: It includes driving wheel. Speed ratio adjusting mechanism and recoding mechanism. The total rotation number and speed of a pair of gears will be passed to the needle and wording wheel of recoding mechanism (11). After speed change caused by driving wheel. The total liquid volume and instant flux through the pipe will be known. Speed ratio adjusting mechanism is used for adjusting and correcting errors of instrument.

HQLCB oval gear flowmeter is installed electrical impulses signal transmitter in the counting mechanism of the HQLC oval gear flowmeter. I.E. One permanent magnet disk is fixed on the transmission shaft at seal of the HQLC flowmeter. New model magnetic sensitive integrated transducer is installed on the counter. The transducer possesses merits such as long life, strong capacity of anti interference, wide working frequency, no spark, fear less of oil, grease and dust, small measurement, convenient installation. The solid teating signals can be got without contact when the magnet accesses to the induction surface with the action distances.



图 2 HQLC 型流量计永久磁铁传动结构图

Permanent magnet driving block diagram of Model HQLC flowmeter

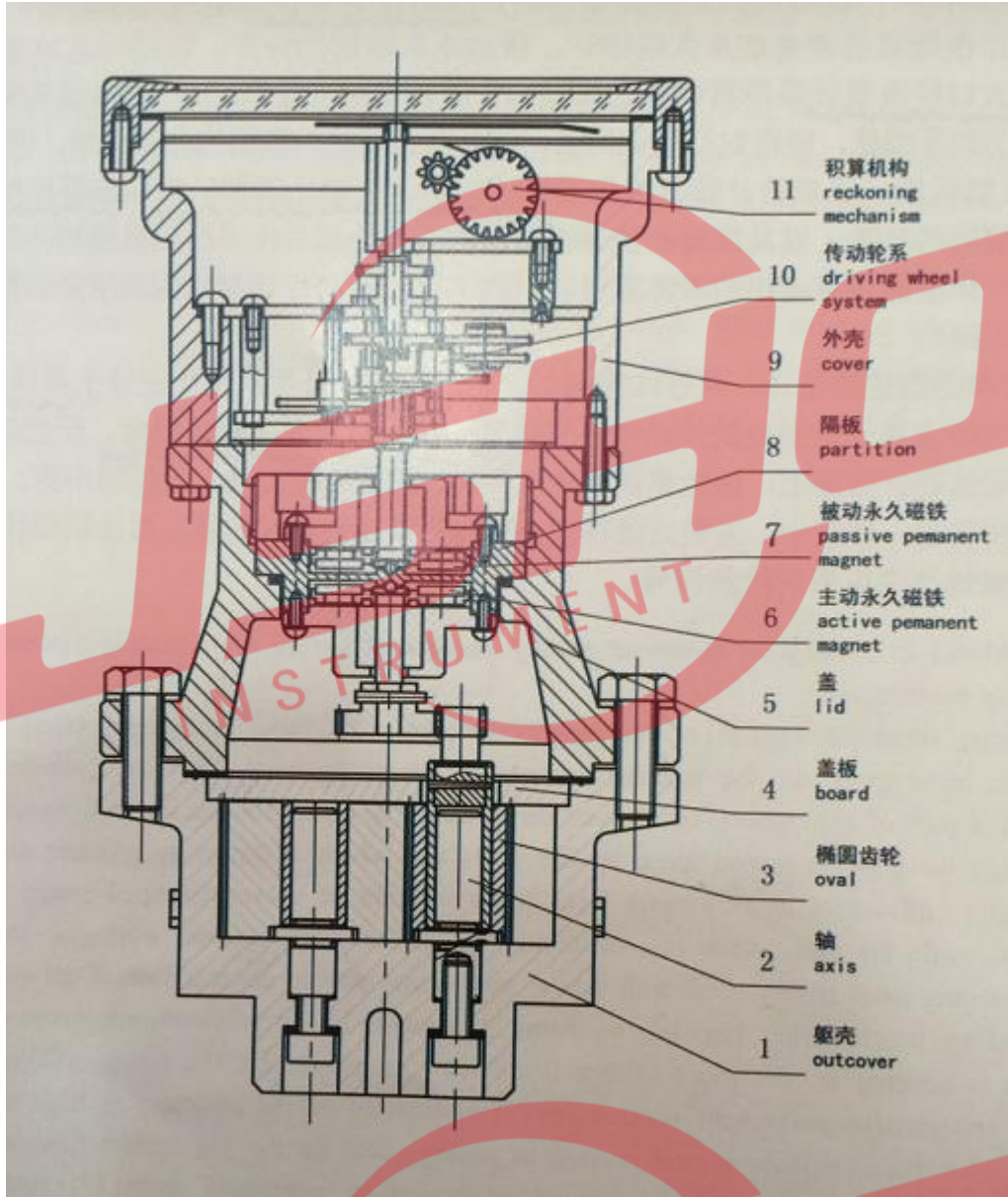

图 3 HQLC 型流量计聚四氟乙烯密封传动结构图

Polytetrafluoroethylene seal driving block diagram of Model HQLC flowmeter

四、主要技术数据 Main technical datas

- . 允许基本误差(%) Basic errors allowance..... ± 0.5 (± 0.2)
- . 最大工作压力(Mpa) Max.working pressure(Mpa).....1.6
- . 管道连接法兰 Connectin flange of pipe.....JB 78-59 79-59
- . 粘度 (mpa.S) viscosity of liquid(mpa.s)
 - 0.5 级.....0.6-200
 - 0.2 级.....0.3-200
- . 被测介质温度($^{\circ}\text{C}$) Temperature of tested medium0-60
- . 流量范围 Flow range(下表)

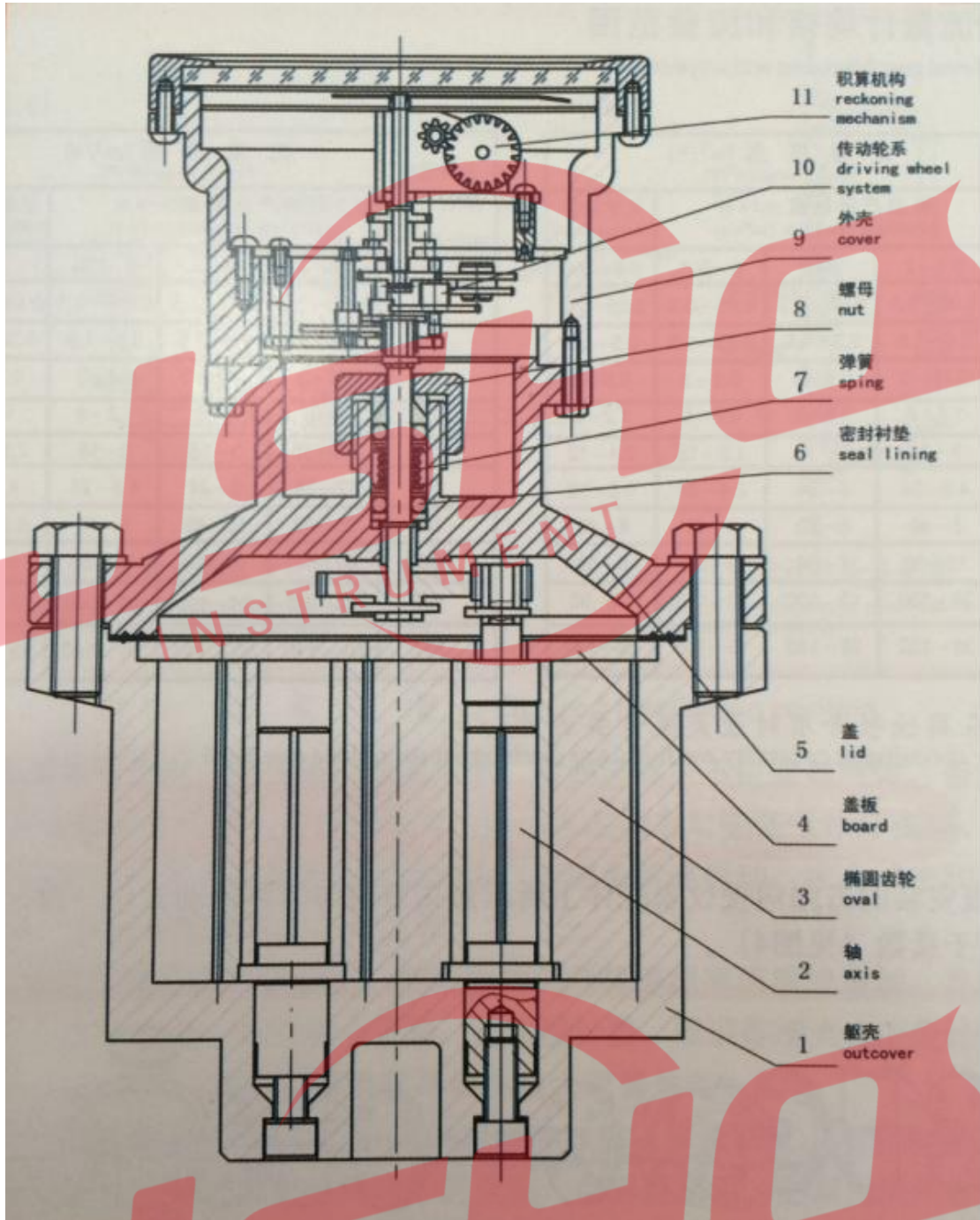
椭圆齿轮流量计规格和流量范围

Specification of oval gear flowmeter and scope of flux

(0.5 级)

(0.2 级)

公称通径 DN (mm) inside nominal diameter(mm)	流量范围 (m3/h)			
	石油产品粘度 (mpa.s) petroleum products (mpa.s)			化学液体 Chemical liquid
	0.6-2	2-8	8-200	0.6-200
10	0.08-0.3	0.06-0.3	0.03-0.3	0.06-0.3
15	0.4-1.5	0.3-1.5	0.15-1.5	0.3-1.5
20	0.75-3	0.5-3	0.3-3	0.6-3
25	1.5-6	0.8-6	0.6-6	1.2-6
40	3-15	2-15	1.5-15	2.4-12
50	4.8-24	3-24	2.4-24	3.8-19
65	8-40	5-40	4-40	6-40
80	10-50	7-50	5-50	8-50
100	20-100	13-100	10-100	15-80
150	30-150	20-150	15-150	25-120

公称通径 DN (mm) inside nominal diameter(mm)	流量范围 (m3/h)			
	石油产品粘度 (mpa.s) petroleum products (mpa.s)			化学液体 Chemical liquid
	0.6-2	2-8	8-200	0.6-200
10	0.08-0.3	0.06-0.3	0.03-0.3	0.06-0.3
15	0.4-1.5	0.3-1.5	0.15-1.5	0.3-1.5
20	0.75-3	0.5-3	0.3-3	0.6-3
25	1.5-6	0.8-6	0.6-6	1.2-6
40	3-15	2-15	1.5-15	2.4-12
50	4.8-24	3-24	2.4-24	3.8-19
65	8-40	5-40	4-40	6-40
80	10-50	7-50	5-50	8-50
100	20-100	13-100	10-100	15-80
150	30-150	20-150	15-150	25-120

注：选用在腐蚀性介质时最大流量要减少 1/3.

Note: When choosing at causticity medium, top discharge must reduce one third.

五、安装与使用 Installation and usage

1、仪表安装的方向应使仪表壳体上所示箭头方向与液体流动方向一致，安装位置注意便于读数（见图4）



图4 安装姿势 Picture 4 Installation position

2、仪表尽量安装在常温场合，不要安装在有害气体及强烈热辐射的场合，防止仪表计数器部分受损害。

3、仪表中的椭圆齿轮轴尽可能安装成水平位置，即刻度盘应安装成垂直位置（分度“0”就在上面），以减少椭圆齿轮与壳体间的摩擦，降低零件的磨损。由于安装位置不同，为了便于读数，可将计数器（表头）旋转90度或180度。（见图5）

4、仪表安装前，管道必须彻底清洗，在整个管路系统中，若无严格的过滤装置时，应在仪表前安装过滤器，以防杂质进入表内。

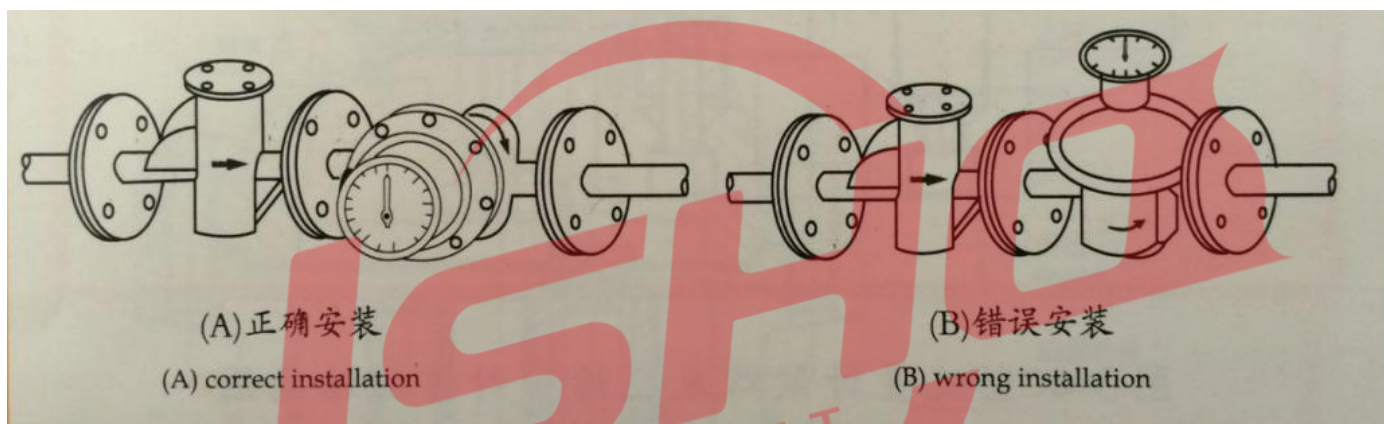
5、仪表应安装在泵的出吕端，流量调节阀应安装在仪表的下游。使用时先打开上游截止阀，然后缓慢开启下游流量调节或截止阀。严禁突然开启或关闭。



图5 安装位置 Picture 5 Installation position

6、仪表在使用时，应使表内流满液体。被测液体内不应混有气体，否则出气和液的混合容积测量不准。液体内混有气体必须在仪表前安装气体分离器。

7、管道中的流量不应急剧增加或减少，应避免管道振动、水力冲击和压力急剧波动等现象，否则将影响仪表正常工作。

8、流量超过规定的最大流量时，椭圆齿轮随着转速提高而磨损增加，且压力损失急剧增加，应避免使用。低于最小流量，虽能通计量，但误差增大。流量计的起动流量约为最大流量的 2%，正常工作流量最好为最大流量的 70%-80%。

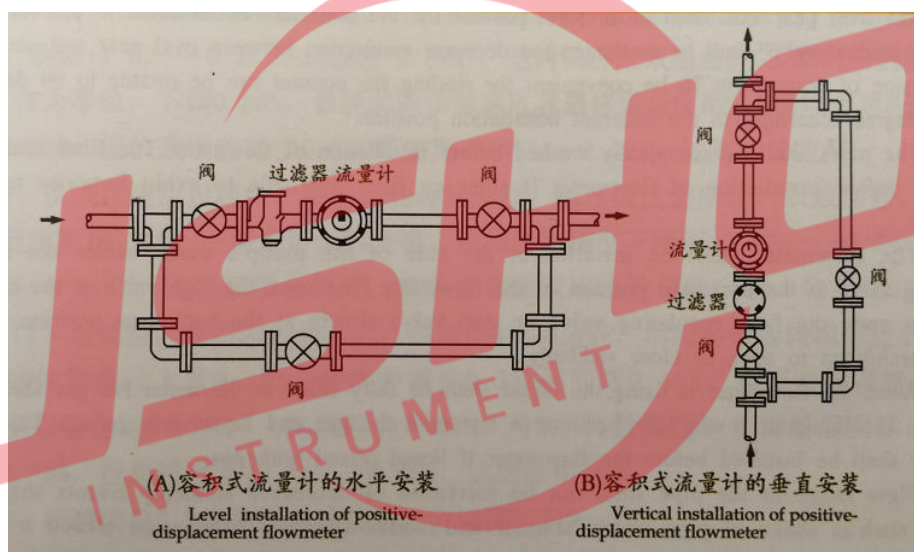
9、用于测量高粘度液体时，一般均将液体加热以降低粘度，然后在管道内流通。当仪表停用后，仪表内充满的液体冷却而变粘，如再要启用，必须用蒸汽在表体外部把液体冲热等方法加热，待仪表内液体粘度降低后才能使用。否则粘液会咬住传动零件，致使仪表损坏。

10、被测液体温度不应高于规定值，超过了仪表甚至会卡住不动。液体温度变化也会造成粘度影响的附加误差。另外，温度增加也造成新月形空间体积增加，使仪表“走得慢”，测量室为铸铁，椭圆齿轮为铸铝时，附加误差+0.14%/100℃。

11、每台仪表出厂时，均用 7 号机械油在室温条件下标定，常温下油的粘度约为 10mpa.s,如用户使用的液体粘度与此相差较大时，可调换双层齿轮。

12、严禁用扫线蒸汽和水通过仪表。

1、 Installation shall keep the direction on the carcass of the flowmeter to be consistent with flow direction of liquid. Installation position shall be convenient for reading. (See picture 4)

2、 The flowmeter shall be installed in the normal temperature place without harmful gas and strong heat radiation to prevent the counter of the flowmeter from coming to harm.

3、 The oval gear axis shall be in level position i.e. The dial shall be installed to the vertical position (graduation "0" shall be on the top) to decrease friction between oval gear and carcass and abrasion of spare parts. To be convenient for reading ,the counter can be rotated to 90 degree or 180 degree according to the different installation position.

4、 The pipes shall be completely washed before installation of flowmeter. The filter shall be installed before installation of flowmeter if filter no filter available to avoid impurity to the flowmeter.

5、 The flowmeter shall be installed at the side of the pump's outlet while the flow regulating valve at the backward position of the flowmeter. First open the stop valve at the upper side, then open the flow regulating valve or stop valve slowly at the backward position .It is strictly prohibited to open or close suddenly.

6、 When the flowmeter is using,the liquid shall be fully filled in the meter.No gas shall be mixed in the liquid or it won't be accurate to test with the gas and liquid mix

cubage. The gas separator shall be installed before the flowmeter if liquid mixed with gas.-

7、 Flow range in the pipe shall not be increased or decreased ruddenly. Events shall be avlided such as shake of pipe, water hammer and sudden fluctuate of pressure etc. Or it will influence normal work of the meter.

8、 Abrasion of the oval gear will be increased with high rotation speed if flux exceeds the max. flux limited. It can be used but errors will be big if the flux less than the min. flux limited. The starting flux is 2% around of the max. one. It's better that normal working flux is 70%-80% of the max. one.

9、 Upon high viscosity liquid tested, it shall be heated to decrease viscosity first and flow in the tube. When flowmeter stops to work, liquid in the foowmeter will be viscous after cooling. If restart to use the flometer, methods such as eating by steam outside the flowmeter to make liquid folw shall be done. The flowmeter can be used after liquid viscosity cecreawed. Or viscous liquid will "bite" driving parts and destroy the flowmeter.

10、 Temperature of testing liquid shall not higher than limited one. If high, the flowmeter will stop to work. Change of temperature will cause additional errors of viscosity influence. Furthermore, cresent-shaped space will be large as increase of temperature and make flowmeter "walk slowly" If the testing room is made by cast iron while oval gear is cast aluminium, additional error is +0.14%/100°C.

11、 Each flowmeter will be markde by No.7 machinery oil under room temperature. Oil viscosity is 10 centipoise under normal temperature. If liquid viscosity difference is large comparing with it, double layer gear can be uesd to replace.

12、 Hose sweeping steam and water is prohibited to flow in the meter.

六、误差调整 Error adjustment

仪表在规定的最小流量和最大流量范围内基本误差不大于 ±0.5%。误差的计算方法以仪表的累计指示流量 $Q_{指}$ 与标准容器实际流量 $Q_{实}$ 之差与 $Q_{实}$ 的百分比表示，即：

$$\text{误差 } E = \frac{Q_{指} - Q_{实}}{Q_{实}} * 100\%$$

仪表较快，误差以 “+” 表示

仪表较慢，误差以 “-” 表示

$Q_{实}$

- 1、设计时的标准双层齿轮是 38/35.在校验时若发现仪表走快了，即出现 (+) 误差。例如+1.02~+0.3% (平均误差+0.66%)，这时将标准双层齿轮 38/35 对应的误差“0”作为零位，下调 0.66%，参照误差调整表取其最接近值 0.62%，调换上对应双层齿轮 41/38，使仪表误差减少 0.62%而变为+0.4~-0.32%，达到合格范围。
- 2、仪表在使用过程中，由于齿轮等的磨损，精度往往会变化，以致超差。只要误差范围不超过 1%，一般均可调到合格。例如仪表精度下降到+0.22%~-0.64% (平均误差-0.21%)，调换双层齿轮时，首先应看原双层齿轮是多少齿，如果是 38/35，则按 (1) 法调整；若是别的齿轮时，例如是 41/38 齿轮，则应将该齿轮相对应的误差+0.62%作零位，上调 0.21%，使误差减少 0.21%而变成 0.41%，参照误差调整表，调换上双层齿轮 40/37. (其误差为 0.43%，与 0.41%最接近)。调整后实际误差 udit0.19%,wygeogyayl+0.41~-0.45%，达到合格范围。
- 3、校验调整 0.2 级椭圆齿轮流量计方法同 1、2 项。
- 4、调换双层齿轮时，先卸下外壳 (图 2、图 3 之 (9))，在其背后拧松轴套 (1) (图 6，下同) 及螺钉 (3)、(4)，更换调整齿轮 (2)，然后转动调整板 (5)，使调整齿轮与传动齿轮 (6)、(7) 啮合正确，再紧固轴套与螺钉。

Error adjustment

The basic min.and max.flow range error allowed is between 0.5%.The caLculation of error is percentage comparing dirfference between accumulating flux showed and actual flux in standard container with actual flux.

1. The standard of double layer gear designed is 38/35.If it is found the flowmeter runs fast when checking, it means" + "errors occurred.For examlle +1.02~+0.3% (average error is +0.66%) .The error of standard double layer gear 38/35 shall be treated as "0" and adjust 0.66% below.Referring to the error registration chart, replace the gears with the corresponding double layer gear 41/38 to decrease 0.62% error and change into +0.4%~-0.32% which is within the qualified scope.

2. Precision of flowmeter will be changed owing to gears'abrasion during usage and lead to ultra-errlr.It can be adjusted up to garde if error range is less than 1%.For example,if precision of meter declined to +0.22% ~-0.64%(average error is -0.21%), firstcheck number of teeth of original double gear. If it is 38/35,adjust as the above No.1.If it is 41/38 gear,corresponding error +0.62% shall be treated as 0,raise 0.21% to make error decline 0.21% and change into 0.41%.Referring to the error registration chart, replace 40/37 double layer gear.(Its error is 0.43% and it is most similar to 0.41%). The actual error will decline 0.19% after adjustment.Precision of meter is +0.41~-0.45% within pualified scope.

3. Means to verify and adjust Grade 0.2 oval gear flowmeter is same as No.1,2.

4. Take off out cover (No.9 in picture 2,3) first and loose axle sleeve(1) at the back of it (See picture 6, same beblow)and nuts (3),(4),replace and adjust gear (2),then turen adjusting board (5) to make adjusting gear and driving gear(6),(7) to joggle correctly, tighting axle sleeve and nuts.

误差调整表
Error registration chart

仪表初校结果 Meter initial verifying results		调整齿轮齿数 Adjustment of gears' teeth	
快或慢 Fast or slow	误差% error %	Z1与齿轮7 啮合 Z1 joggle with gear 7	Z2与齿轮6 啮合 Z2 joggle with gear 6
慢 (-) 仪表指示值小于实际值 Slow (-) digital meter showed to less than the actual one	2.63	39	35
	2.34	40	36
	2.06	41	37
	1.80	42	38
	1.55	43	39
	1.31	44	40
	1.09	45	41
	0.88	46	42
	0.74	35	32
	0.48	36	33
0.23	37	34	
0.00	38	35	
慢 (+) 仪表指示值大于实际值 Slow (+) digital meter showed to less than the actual one	0.22	39	36
	0.43	40	37
	0.62	41	38
	0.81	42	39
	0.99	43	40
	1.16	44	41
	1.32	45	42
	1.47	46	43
	1.54	31	29
	1.75	32	30
	1.95	33	31
	2.14	34	32
	2.31	35	33
	2.48	36	34
	2.63	37	35
2.78	38	36	
2.92	39	37	
3.05	40	38	
3.17	41	39	

传动比调整机构
Adjustment mechanism
of drive ratio

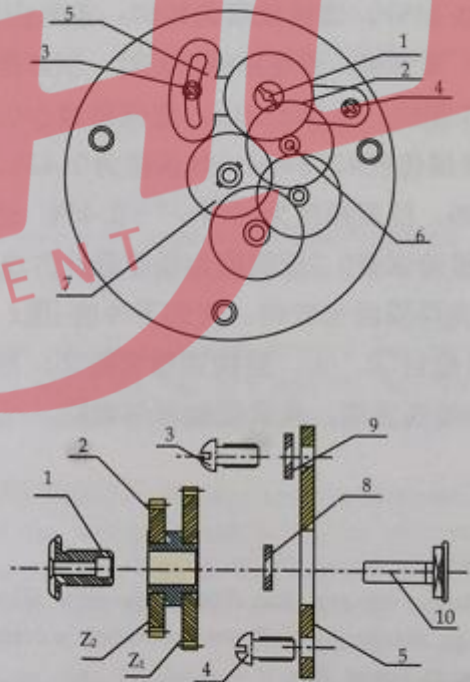

1、轴套 2、调整齿轮 3、4、螺钉
5、调整板 6、7、传动齿轮
8、9、垫片 10、特殊头螺钉

1.axle sleeve 2.adjusting gear
3,4.nuts 5.adjusting board
6,7.driving gear 8,9.washer
10.bolt

图 6 传动比调整机构及结构示意图

Adjustment mechanism of drive ratio & structure sketch map

七、故障的检查与排除 Fault examination and clearing

现象 Phenomena	原因 Reason	措施 Measures	备注 Remark	
1、椭圆齿轮不转。 Oval gear stops turning	1、安装时有杂质落入表内，卡住椭圆齿轮。 Impurity mixed in the meter and the oval gear blocked	拆洗，洗涤后重新安装，按椭圆齿轮上所标记号安放。 Unpick and wash, reinstall as mark on the oval gear	新表常易发生，按所标记号安放椭圆齿轮。 New meter easy to happen, oval gear laid as marks.	
	2、被测液体不清，过滤器为杂质塞满。 There is mixture in liquid tested, filter filled with impurity	洗涤过滤器，清除杂质。 Wash filter and clear impurity.		
	3、被测液体压力过低。 Pressure of liquid tested is too low	增加压力。 Increase pressure		
2、椭圆齿轮转动但指针不动。 Oval gear turns while needle doesn't turn	1、传动轮系卡住。 Drive wheel blocked	清洗杂质，并添加润滑油。 Clear impurity and add lubricant		
	2、齿轮铆合松动。 Loss of gear riveting	重新铆紧齿轮。 Rereviet gear		
3、指针回转时有抖动现象。 Joggling when needle turns back	流量过大，超过规定值 Flux exceed the max. specified flux	调整流量至规定值。 Adjust the flux to specified value.		
4、椭圆齿轮转动时有不正常的噪音。 Offnormal noise during turning of oval gear	流量过大，超过规定值。 Flux exceed the max. specified value	调整流量至规定值。 Adjust the flux to specified value.		
5、指针反转，字轮转位反向。 Needle reverse turn	液体流动方向与表壳所示箭头方向相反。 Direction of flow is opposite to the arrow direction marked on the out cover of meter	拆卸，按所标方向安装。 Unpick and reinstall according to the direction marked.		
6、误差过大 Large error	负差 Minus error	1、流量过少，低于规定值 Flux less than min. specified value.	换较小口径流量表 Replace flowmeter with small caliber	向生产厂配购调整齿轮或送厂修理。 Buy adjusting gear to the manufacturer or send to repair
		2、旁路泄露 Leakage of by pass	检查旁路，防止泄露 Check bypass to prevent leakage	
	3、使用年限过久，椭圆齿轮等磨损较多。 Much abration of oval gear as long time usage	按误差变化值，换调整齿轮 Replace adjusting gear as per change value of error		
	正差 Plus error	4、液体内含有气体。 Gas included in liquid	表前增装气体分离器及防止法兰联接处渗漏。 Install gas separator before meter and prevent leakage at the join of flange	
		5、液体粘度与校验液体粘度相差过多。 Viscosity difference between liquid tested and verified	按误差变化值，换调整齿轮 Replace adjusting gear as per change value of erro	

八、外形及安装 Profile and installation

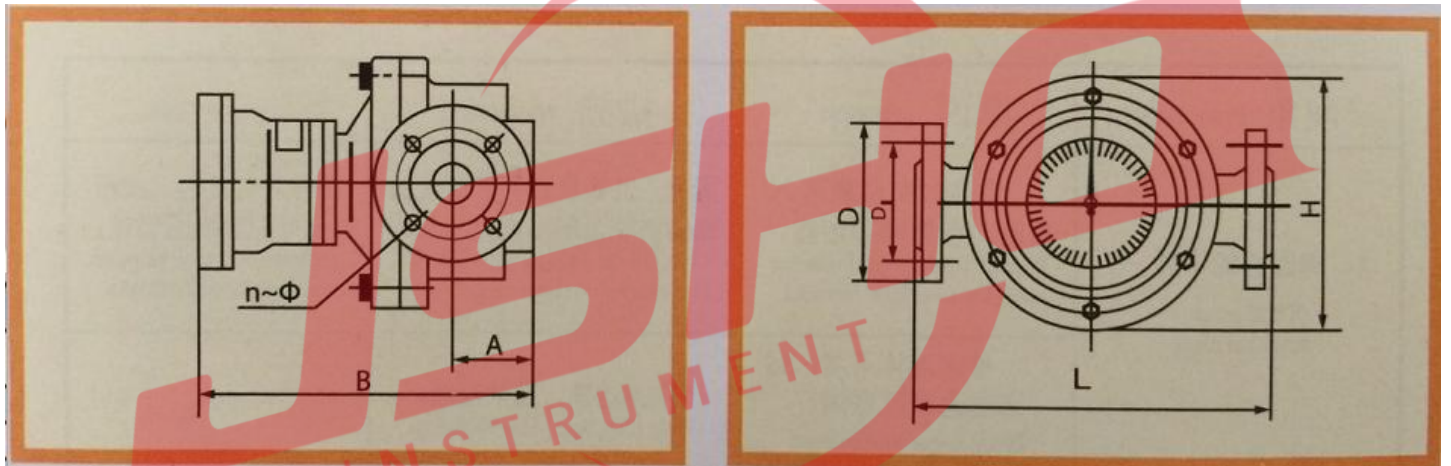

L C- 系列椭圆齿轮流量计外形尺寸 (铸铁、铸钢、不锈钢)
 LCB- series ellipse gear flowmeter exterior size (cast iron\cast steel\ stainless steel)
 单位: mm

型号	L	H	B	A	D	D1	n(个)	Φ
LC-10	82	128	188	27	两端3/8" 锥管螺纹 (内丝) 出厂配 3/8" / 1/2" 变径外丝两只			
LC-15	180	124	240	48	95	65	4	14
LC-20	200	124	256	57	105	75	4	14
LC-25	245	184	244	67	115	85	4	14
LC-40	252	184	270	83	145	110	4	18
LC-50	340	255	324	95	160	125	4	18
LC-65	340	255	322	99	185	145	4	18
LC-80	420	310	390	130	200	160	8	18
LC-80I	340	255	322	99	200	160	8	18
LC-100	440	330	450	159	220	180	8	18
LC-150	450	360	470	180	285	240	8	22

LPG系列过滤器外形尺寸

LPG series filter exterior size

单位: mm

仪表型号 Model	公称口径 DN	总长 L	总宽 H	总高 B	法兰 D	法兰孔 D1	螺栓孔 n-Φ
LPG-15	15	152	95	126	95	65	4-Φ14
LPG-20	20	180	105	160	105	75	4-Φ14
LPG-25	25	180	115	155	115	85	4-Φ14
LPG-40	40	257	145	258	145	110	4-Φ18
LPG-40Y	40	220	145	210	145	110	4-Φ18
LPG-50	50	305	165	302	160	125	4-Φ18
LPG-50Y	50	240	160	255	160	125	4-Φ18
LPG-65	65	305	185	302	185	145	4-Φ18
LPG-80	80	360	212	351	200	160	8-Φ18
LPG-100	100	413	240	420	220	180	8-Φ18
LPG-150	150	500	370	540	285	240	8-Φ22

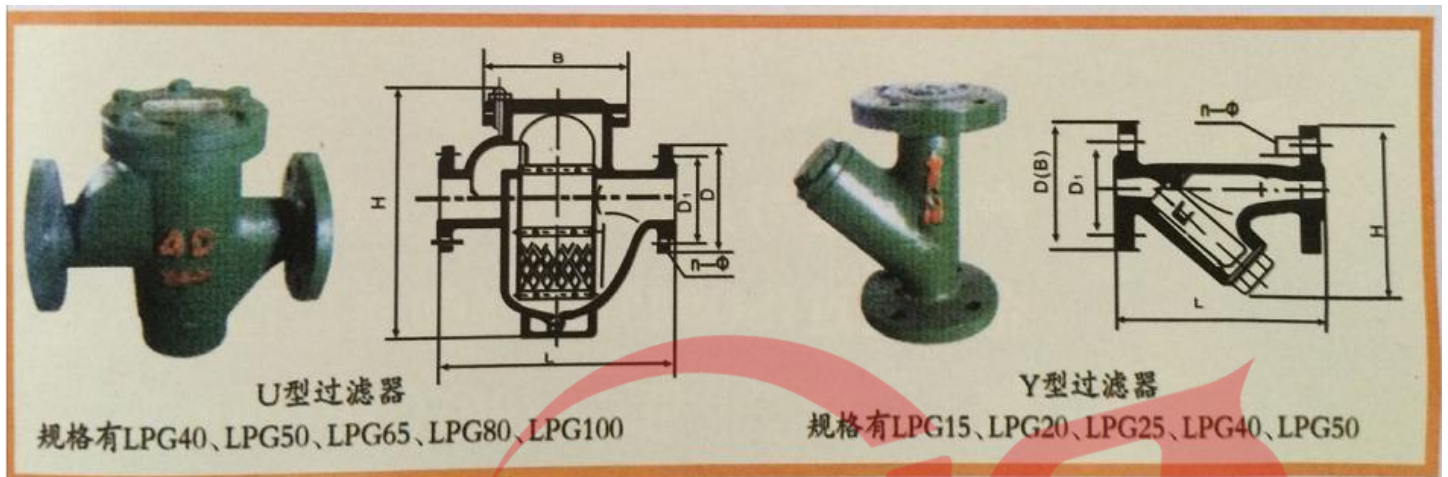

九、HQLCB 型流量计技术参数 Technological parameter of HQLCB flowmeter

1、接线

接线插头上有“1”、“2”、“3”引脚序号，标号“1”、“2”接12VDC(“1”接正极，“2”接负级)，“3”接微机输入信号。

2、技术参数

工作电压: 12VDC; 寿命: > 10⁷次; 工作温度: -10~+55℃
工作频率: 脉冲/升; 功耗: 不大于 90mV; 仪表编号:

1.wire splice:

There are No.1,2,3 mks on connection plug. No.1,2 connects with 12VDC(NO.1 with anode while

No.2 with cathode) No.3 connets with input single of microcomputer

2.Technological parameter:

Working voltage: 12VDC

life: 107 times

Working temperature: -10---- +55℃

Working frepquence: _Pulse/Litre

Power: less than 90 mw

Meter No:

回零流量计简介

Brief introduction of returntozero flowmeter



回零流量计是在 HQLC 型流量计上增加了一套可回零的计数器，使用时顺时针旋转（3）可把回零计数器回到零位，掀下（2）逆时针旋转可把指针回到零位，使用回零计数器时不影响累积计数测量。

Returntozero flowmeter adds a set of zero adjustment counter on the HQLC flowmeter. Turn (3) clockwise can make counter return to zero.Push (2) anticlockwise can make needle return to zero to make counter counting without influence of accumulating counter.

流量计菜单设定步骤:

1. 按键定义:

名称	说明
设定	<ul style="list-style-type: none">测量状态下, 按一下则进入设置状态在设置状态下, 显示参数符号时, 按一下进入下一组参数或返回测量状态
移位	<ul style="list-style-type: none">在测量状态下切换显示瞬时流量和涡轮频率在设置状态下: ① 调出原有参数值 ② 移动修改位
确认	<ul style="list-style-type: none">在测量状态下无效在设置状态下, 存入修改好的参数值, 或者查看下一参数
向上	<ul style="list-style-type: none">在测量状态下无效在设置状态下增加参数数值或改变设置类型
向下	<ul style="list-style-type: none">在测量状态下无效在设置状态下减小参数数值或改变设置类型

2. 设定方法:

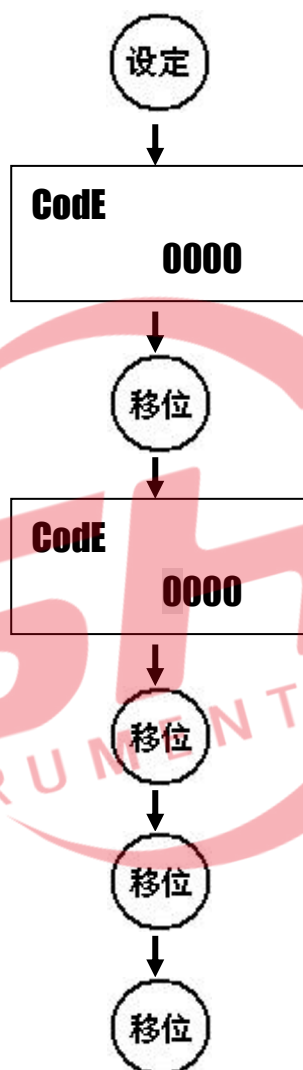

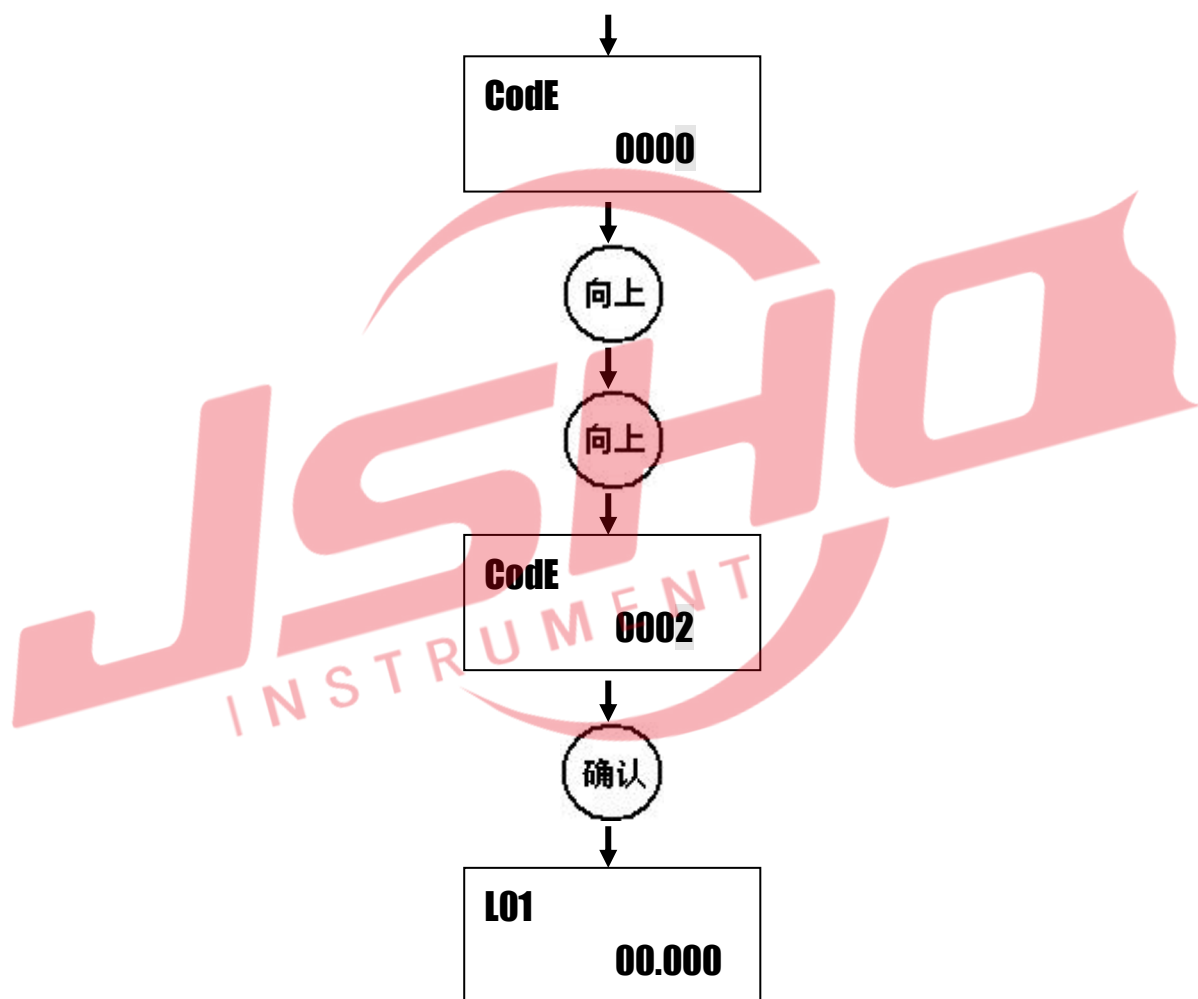

一级菜单（默认密码：0002）：

L01	瞬时流量小数点位置0~4。0~4顺序对应0.0000, 00.000, 000.00, 000.0, 0000。该项可不关心。
L02	流量系数小数点位置 0~4。0~4顺序对应0.0000, 00.000, 000.00, 000.0, 0000。该项可不关心。
L03	传感器流量系数，单位：1/升；
L04	介质的密度值，单位：t/m ³ ，默认为1.000，此项可做为流量修正因子。
L05	瞬时流量计量单位：0~3。 0: l/m; 1: m ³ /min; 2: m ³ /h; 3: l/h。
L06	滤波时间设定 (s)：1~20， 默认设置为1；
L07	小信号切除数值 0—9999， 默认为0，不打开信号切除，可根据实际情况，切除一个小流量数值。
L08	折线修正功能选择：0: OFF; 1: ON，默认为OFF，不打开折线修正功能。非厂家人员不能修改该参数。

L09	20mA 的量程设定；（干电池供电无此项）。
-----	------------------------

如果 L08(折线修正功能)设置为"ON",按"设定键"则进入分段频率和分段系数修改。 如果 L08 设置为"OFF",按下"设定键"就退出设定状态。

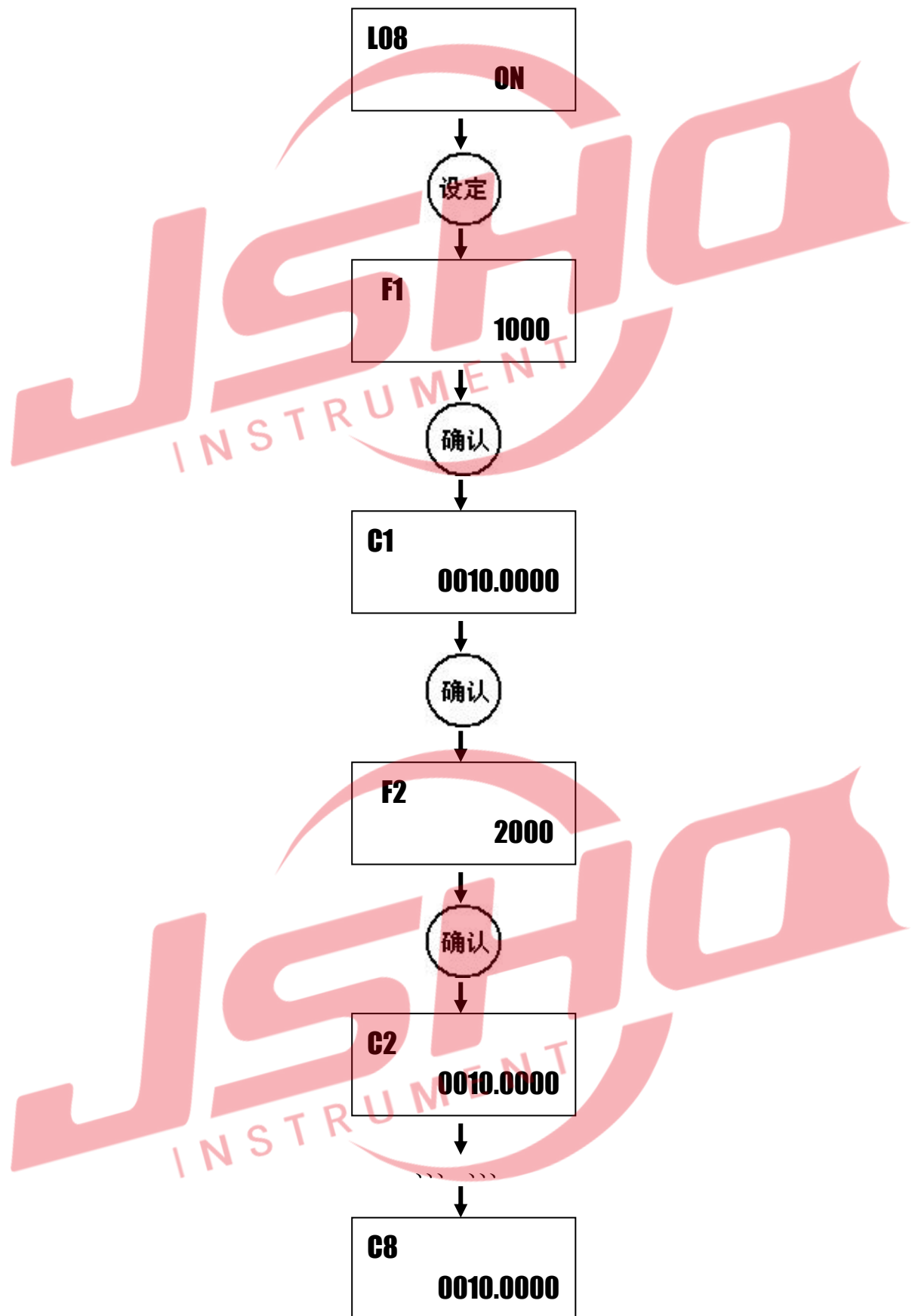



退出设定状态。

折线修正菜单：

F1	涡轮流量传感器的第一段分段频率值 (Hz)，最小；
C1	涡轮流量传感器的第一段流量系数 (1/升)；
F2	涡轮流量传感器的第二段分段频率值 (Hz)；
C2	涡轮流量传感器的第二段流量系数 (1/升)；
F3	涡轮流量传感器的第三段分段频率值 (Hz)；
C3	涡轮流量传感器的第三段流量系数 (1/升)；
F4	涡轮流量传感器的第四段分段频率值 (Hz)；
C4	涡轮流量传感器的第四段流量系数 (1/升)；
F5	涡轮流量传感器的第五段分段频率值 (Hz)；
C5	涡轮流量传感器的第五段流量系数 (1/升)；
F6	涡轮流量传感器的第六段分段频率值 (Hz)；
C6	涡轮流量传感器的第六段流量系数 (1/升)；
F7	涡轮流量传感器的第七段分段频率值 (Hz)；
C7	涡轮流量传感器的第七段流量系数 (1/升)；
F8	涡轮流量传感器的第八段分段频率值 (Hz)；
C8	涡轮流量传感器的第八段流量系数 (1/升)，最大。

二级菜单（默认密码：2222）

L11	外部磁钢清零许可。ON：允许；OFF：不允许。
L12	"向下键"清零许可。ON：允许；OFF：不允许。

三级菜单（超级密码固定为 6210）：

BA0	4-20mA 零点调节;可不关心.电池供电无此项。
BA1	4-20mA 满度调节;可不关心.电池供电无此项。
L13	一级菜单密码修改(0002);
L14	二级菜单密码修改(2222);
L15	累积流量整数部分清零;
L16	累积流量小数部分清零。

红器自控（江苏）有限公司

地址：江苏省淮安市金湖县戴楼集中工业区润楼路16号

电话：0517-86880701

传真：0517-86880702

邮编：211600

网址：<http://www.0517yqyb.com>

E-mail：yb86880701@163.com